



SHENZHEN GENERAL SYSTEMS CO., LTD

GS ROAD BLOCKER SERIES

## ROAD BLOCKER GS100



### **Product Description**

The GS Series of rising vehicle blockers are designed to prevent unauthorized vehicles from crashing through controlled entry and exit points.

Built for fast reliable and efficient operation, these barriers are capable of withstanding high impact loads and are ideally suited for installation at toll collection booths where normal traffic is controlled by high speed boom gates.

Visual surveillance is recommended during the operation of the barrier.

### **Functions and Features**

Strong and durable structure, great capacity of weight bearing;

Stable movement, low noise;

Workable in bad weather environment;

Adopting low hydraulic pressure driving measure, few failures happening, dependable and long serving life;

Simple and easy maintenance;

Compatible with other controlling facilities to achieve automatic control;

Manual operation mode can be used in power off or accidental cases; the raised gate plate can be put back to its horizontal position by manual operation.

Main hydraulic components are imported well-known products, which ensure the dependable quality and long serving life.

## Technical Parameters

Vehicle passing capacity: available for the passing of middle or small size heavy-duty vehicles  
System power: 1.5KW/380V

Opening time: <4.5S

Closing time: <5S

Working temperature: -20 ° --- 50 °

Storage environment: -10 ° --- 75C, keeping way from rain, wet and dust

## Exterior Structure

Main composing

Hydraulic road barrier is composed of main machine, hydraulic driving system, and electric control system. Main machine is composed of driving unit and balancing unit, etc., put on the passageway of vehicles; the moving gate plate is even with the road surface.

The hydraulic driving system is composed of 3-phase motor, hydraulic pump, hydraulic oil cylinder, assembled valve parts, oil box, and pipelines, etc. This system shall be installed at the place easy to operate of maintenance.

Electric control system provides the power to hydraulic driving system and controls the working status of electromagnetic commutating valve. This system can use the special electric control box made by our company, or use other box according to overall control system and control mode the user has selected and set. The electric control box shall be installed at the place easy to operate, keeping away from rain and wet. It needs a good earthing.

## Exterior size

Main machine exterior size, see fig.1 and table A.

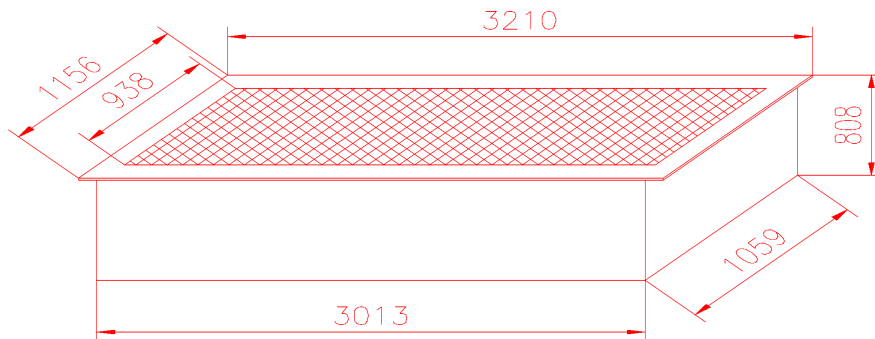

Model No.	L1	L2	L3	W1	W2	H
GS009	2230	2000	2030	736	510	573
GS100	2930	2700	2730	780	560	700

**Table A** , Main machine exterior size of hydraulic road barrier

Hydraulic pump exterior size, see **fig 2, Table B**

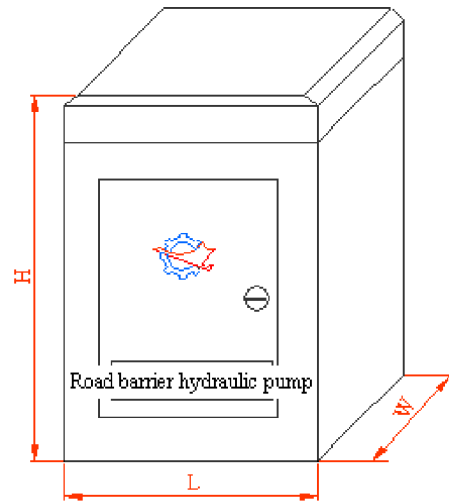
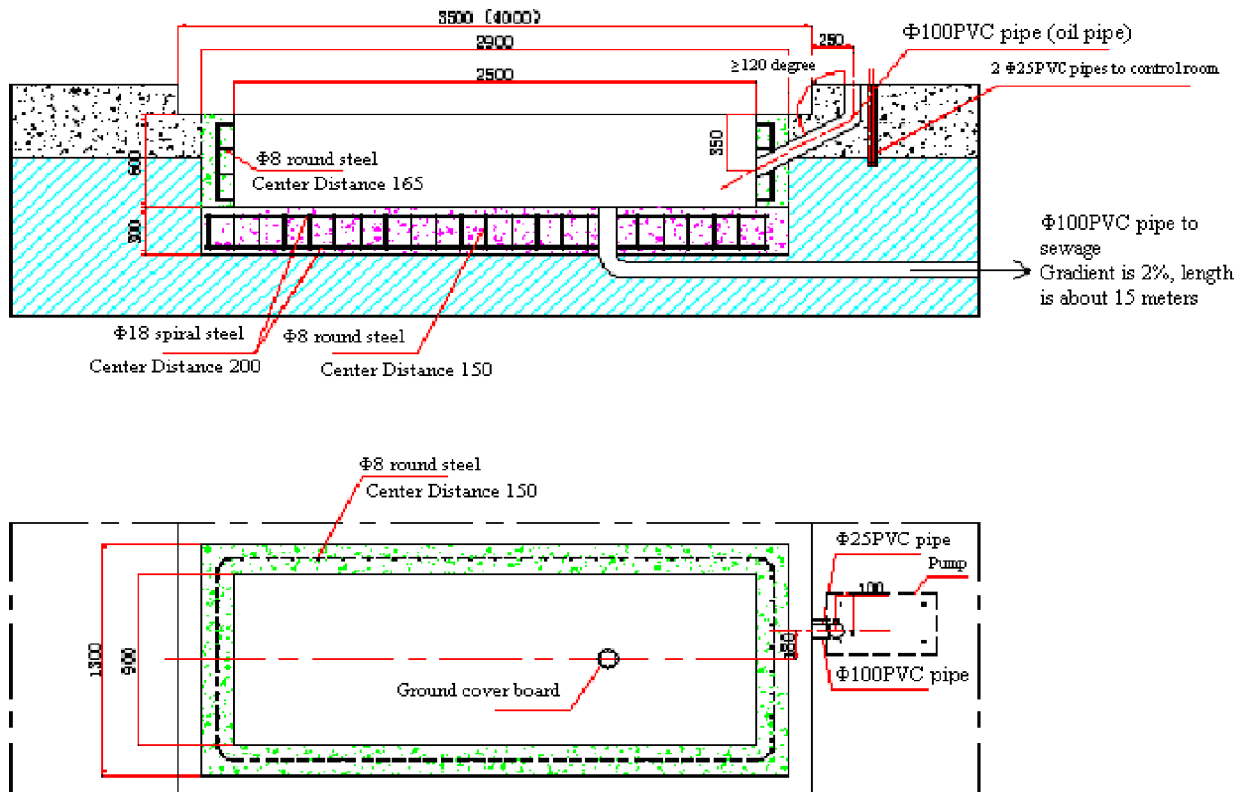

Fig.2 Road barrier hydraulic pump exterior size

Model	L	W	H
GS009	650	400	1000
GS100	650	400	1000

**Table B, Road Blocker Hydraulic pumps exterior size**

### Site Preparation of GS Road Blockers



### System Installation of GS Road Blocker Main Machine

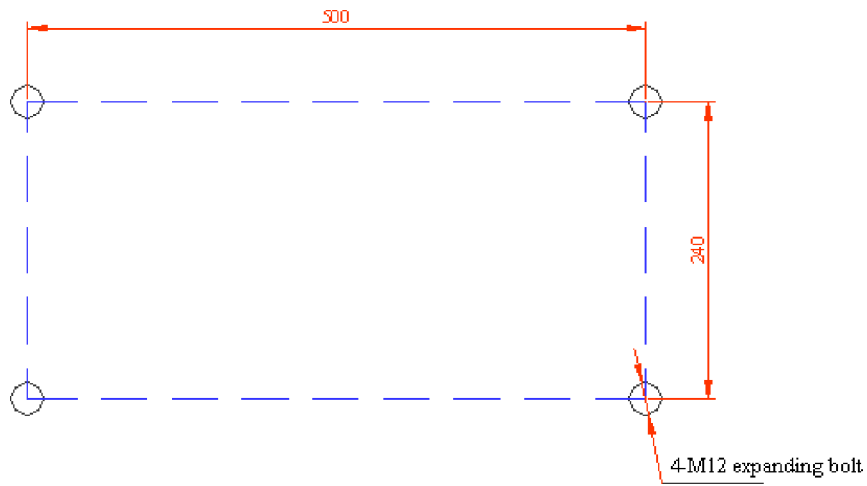

**System Installation of GS Road Blocker Hydraulic Pump**

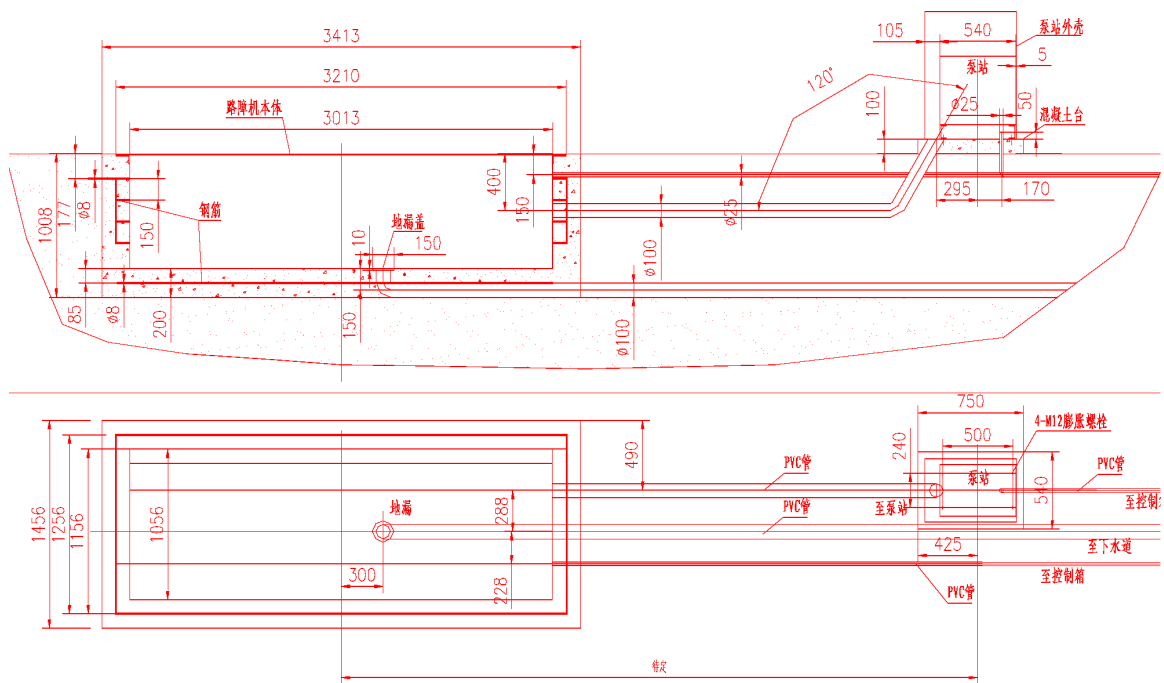

**System Installation of GS Road Blocker Main Machine**